

DUFT- TRIANGLE CORNER FLOOR DRAIN

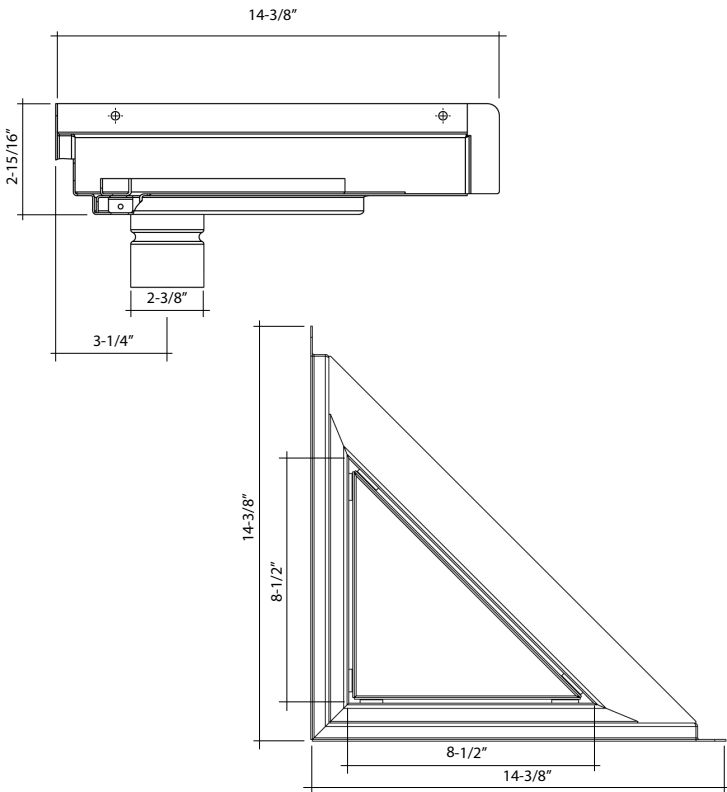

DUFT-T9

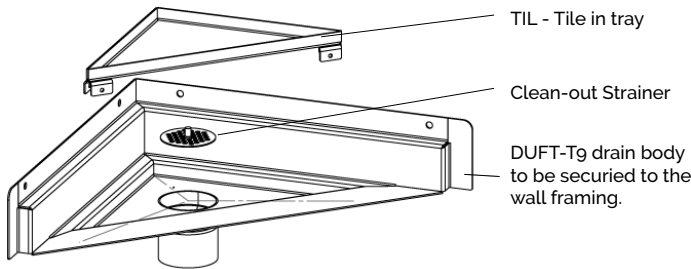

Model DUFT-T9-TIL-BSS

PROJECT: _____

NOTE: _____

NEO ANGLE CORNER DRAIN

DUFT Series is a one of a kind neo angle corner drain, that is a two-piece low profile floor drain system specifically designed for a truly invisible floor drain that is an easy installation and bonded waterproofing membrane. DUFT corner drain is designed to accommodate large, small format tiles or stone installations in a shower with a single plane slope to the drain. The DUFT corner drain is designed for commercial or residential projects and is intended for interior applications.

ADVANTAGES

- Single slope to drain
- Allows for the use of any size tile format tile
- Tile in grate available to match floor tile
- Made from heavy duty 304 stainless steel provides for long-lasting performance with passivated rust-proof finish

SUITABLE SUBSTRATES

- Concrete
- Exterior Glue Plywood (Interior Only)
- Cement Backer Board
- Cement Mortar Bed

PRODUCT ATTRIBUTES

- Application: Commercial and Residential
- Color/Finish Category: Stainless Steel
- Color/Finish Name: Passivated
- Diameter: 2 in
- Drain Opening: 2 in
- Fits Pipe Size: 2 in
- Material: Stainless Steel
- Material Type: AISI-304 SS (AISI-316 available upon request)
- Specifications - ASME: ASME A 112.18.2 (Pending)
- Specifications - CSA Certified: B 125.2 (Pending)
- Style Name: DUFT Series

| MODEL: | GRATE STYLE: | FINISH: |
|---|---|--|
| <input checked="" type="checkbox"/> DUFT-T9 | <input checked="" type="checkbox"/> TIL - Pietra Style (Tile in Tray) | <input checked="" type="checkbox"/> BSS- Brushed Stainless Steel |